

A Simple Model for the Determination of Jackknifing

Oren Masory
Florida Atlantic University
Boca Raton, FL 33431

Grainer Thomas

IFMA – Institut Francais De Mechanique Avancee
Campus de Clermont, Les Cezeaux BP 265-63175, France

Abstract

Jackknifing is uncontrolled braking of a truck-trailer combination which causes the trailer rotates relative to tractor and as a result extends to adjacent lanes, causing in many cases sever accidents.

In this paper a simple two dimensional model is presented. The model includes parameters such as truck's and trailer's dimensions, coefficients of friction, masses, location of the load on the trailer etc. Based on this model simulation program, which allow the user to determine whether or not jackknifing will occur, was written. Simulations results for few cases are presented.

Nomenclature

- L_1 - Distance between the tractor's front axle and its GC
- L_2 - Distance between the tractor's rear axle and its GC
- L_3 - Distance between the tractor's rear axle and the trailer's GC
- L_4 - Distance between the trailer's GC and its rear axle
- W_c - Tractor's weight
- W_t - Trailer's weight (including load)
- w - Tractor/trailer width
- b - Lateral location of the trailer's center of gravity
- μ_f - Coefficient of friction on the tractor's front tires
- μ_m - Coefficient of friction on the tractor's rear tires
- μ_r - Coefficient of friction on the trailer's rear tires
- μ_{rr} - Coefficient of friction on the trailer's right rear tires
- μ_{rl} - Coefficient of friction on the trailer's left rear tires
- I_t - Mass moment of inertia of the trailer about the Z-axis
- F - Horizontal force acting on the kingpin
- P - Vertical force acting on the kingpin
- N_f - Normal force on the tractor's front axial
- N_m - Normal force at the tractor's rear axial
- N_r - Normal force at the trailer's rear axial
- N_{rr} - Normal force at the trailer's right rear wheels
- N_{rl} - Normal force at the trailer's left rear wheels

Introduction

At the present, the truck transport is one of the cornerstones of the economy of the United States. Trucking is vital to the US economy. The American Trucking Association states, "Trucks move most of America's freight and are the transportation backbone of the American economy...the trucking industry accounts for 81% of the country's freight revenue." [1]

This massive flow of products and materials can be easily interrupted, however, by a variety of potential accidents especially semi-trailer accidents that often occur as the truck and the trailer jackknife. Hence, in 2000, 457,000 large trucks that vehicles which weight rating are greater than 10,000 pounds; were involved in traffic crashes in the United States; 4,930 were involved in fatal crashes. A total of 5,211 people died, 12 percent of all the traffic fatalities reported in 2000, and an additional 140,000 were injured in those crashes. Such accidents can close highways for hours, to say nothing of the threat to the lives of truck drivers and car passengers.

Jackknifing might cause a very severe accident due to the fact that the trailer, which rotates about the tractor, extends to adjacent lanes blocking the incoming or following traffic. A full understanding of this phenomenon is therefore critical for accident reconstruction and braking system design.

Previous work on trailer/truck jackknifing include: Timothy V. Fossum and Gilbert N. Lewis presenting a differential equation [2] which is a model for the position of a trailer relatively to the cab which is pulling it. Chieh Chen and Masayoshi Tomizuka from the University of California, Berkeley [3] proposed a modeling approach designed to prevent jackknifing and furthermore reduce tracking errors of the trailer. Some work was done in the University of Windsor, Ontario, determining the equations of motion of tractor/trailer combination. The linearized equations were written in terms of the lateral speed of the truck, the yaw rate of the truck, and the sway angle of the trailer. Finally, the stability of the system had been evaluated by performing an eigen value analysis on the matrix yielded from the previous equations [4]. A general method of deriving dynamic models for any configuration of heavy duty vehicles, including vehicles with N units, is presented in appendix [5]. By the way, commercial

heavy vehicle research at the California Partners for Advanced Transit and Highways (PATH) program has focused on the development of controllers for partially to fully autonomous driving environments. A multi-body dynamic model of a tractor semi-trailer has been developed using a commercially available dynamic analysis software program to predict any one of the many failure modes such as rollover or jackknifing that are common to articulated heavy vehicles [6]. A worst-case scenario generation algorithm able to find the input combination which is most detrimental for truck rollover or jackknife when the steering and braking inputs of a truck are limited below a certain threshold value, was also presented [7]. Many truck brake producers such as Radlinski & Associates, Inc working on the same topic also developed anti-jackknife devices [8]. The aim of those works has been to figure out a dynamical model able to determine whether the articulated truck would jackknife or not, which required the knowledge of a lot of very specific parameters.

This paper presents a simple two dimensional model, which is an extension of a one dimensional stick model. The model accommodates variables, which could not be treated with one dimensional mode, and therefore, through simulations, the effect of these variables on the jackknifing phenomena can be studied. These variables include tractor/trailer lateral dimensions, location of the center of gravity of the trailer (in order to treat load position on the trailer), coefficient of friction for each on the tire and other. As a result, more realistic analysis and can be performed while maintaining the simplicity of the model.

Two-dimensional model

The model assumes no motion in the vertical direction (Z-direction). Thus, the sum of the forces in this direction and the sum of the moments about the Y-axis are zero. Using the dimensions of the tractor-trailer combination shown in Figure 1 and the vertical forces acting on the tractor and the trailer are shown in Figures 2 and 3 respectfully, the reactions at the wheels and the force at the king pin can be determined.

Referring to Figure 2 the static equilibrium is given by:

$$\sum F_z = N_r - W_t + P = 0 \quad (1)$$

$$\sum M_y = N_r L_4 - P L_3 = 0 \quad (2)$$

Solving equations 1 and 2 yields the normal forces acting on the trailer's tires and the vertical force on the king pin:

$$P = W_t \frac{L_4}{(L_4 + L_3)} \quad (3)$$

$$N_r = W_t \frac{L_3}{(L_3 + L_4)}$$

Once N_r and P are known, N_m and N_f , the reaction forces on the tractor, can be easily found using the same

methodology. Summation of the forces acting on the tractor in the Z-direction and the moments about the Y direction (refer to Figure 3):

$$\sum F_z = N_f + N_m - W_c - P = 0 \quad (4)$$

$$\sum M_y = N_m L_2 - P L_2 - N_f L_1 = 0 \quad (5)$$

Solving equations 4 and 5 yields the forces acting on the front and rear tires of the tractor:

$$N_m = W_t \frac{L_4}{(L_4 + L_3)} + W_c \frac{L_1}{L_1 + L_2} \quad (6)$$

$$N_f = W_c \frac{L_2}{(L_2 + L_1)}$$

To determine the reactions on the left and right tires of the trailer, N_{rl} and N_{rr} , the same approach is used. The sum of the moments about Y and X axis should be zero:

$$\sum M_x = (N_{rl} - N_{rr}) \cdot \frac{w}{2} - W_t \cdot (b - \frac{w}{2}) = 0 \quad (7)$$

$$\sum M_y = (N_{rl} + N_{rr}) \cdot L_4 - P \cdot L_3 = 0 \quad (8)$$

Solving equations 7 and 8 yields:

$$N_{rr} = \frac{W_t}{w} \cdot \frac{L_3}{L_3 + L_4} \cdot \left(\frac{w}{2} - \frac{L_3 + L_4}{L_3} \cdot (b - \frac{w}{2}) \right) \quad (9)$$

$$N_{rl} = \frac{W_t}{w} \cdot \frac{L_3}{L_3 + L_4} \cdot \left(\frac{w}{2} + \frac{L_3 + L_4}{L_3} \cdot (b - \frac{w}{2}) \right)$$

In order to determine the friction forces acting on the tires, it is assumed that the coefficient of friction, μ_r , is independent of the tire's sliding direction. Figure 4 shows the velocities of the trailer during a severe braking. Accordingly, Figure 5 illustrated the horizontal forces acting of the tractor and the trailer during braking.

The angle β is given by:

$$\beta = \arctan\left(\frac{\dot{\theta}(L_3 + L_4) \cos(\theta)}{\dot{X} + \dot{\theta}(L_3 + L_4) \sin(\theta)}\right) \quad (10)$$

and the angle α is given by:

$$\alpha = \beta + \theta \quad (12)$$

The translation motion for the tractor/trailer combination, the tractor and the trailer can be described by equations 13, 14 and 15 respectfully:

$$\ddot{X} = \frac{-1}{(M_c + M_t)} (N_f \mu_f + N_m \mu_m +$$

$$(N_{rr} \mu_{rr} + N_{rl} \mu_{rl}) \cos(\beta)) \quad (13)$$

$$M_c \ddot{X} = F - N_f \mu_f - N_m \mu_m \quad (14)$$

$$M_t \ddot{X} = -F - (N_{rr} \mu_{rr} + N_{rl} \mu_{rl}) \cos(\beta) \quad (15)$$

The force on the kingpin, F , can be determine by:

$$F = \frac{1}{(M_c + M_t)} \left[M_t (N_f \mu_f + N_m \mu_m) - \right. \\ \left. M_c (N_{rr} \mu_{rr} + N_{rl} \mu_{rl}) \cos(\beta) \right] \quad (16)$$

The equation describing the rotation of the trailer is determined by summing the moments about the trailer's center of gravity:

$$I_t \ddot{\theta} = -F \left(\left(b - \frac{w}{2} \right) \cos(\theta) - L_3 \sin(\theta) \right) \\ + N_{rl} \mu_{rl} ((w - b) \cos(\alpha) - L_4 \sin(\alpha)) - N_{rr} \mu_{rr} (b \cos(\alpha) + L_4 \sin(\alpha)) \quad (17)$$

Equation 17 is a nonlinear equation in the form $\ddot{\theta} = f(\theta)$ that is solved numerically with the initial conditions $\theta(0) = \theta_o$, $\dot{\theta}(0) = 0$ and θ_o assumes a very small value.

Simulation Results in special cases

The model described above was simulated using Simulink (an object oriented programming tool provided by Matlab). The program allows the user to set values to all parameter shown in the *Nomenclature*. The nominal values used in the simulation were adopted from reference [3] and are shown in Table 2.

Although any rotation of the trailer relative to the tractor might be considered as jackknifing, the probability of collision is higher if the trailer penetrates adjacent lanes. Therefore, jackknifing was determined by evaluating the value of θ when the tractor/trailer comes to stop. If the trailer crossed to adjacent lane it is considered that jackknifing occurred.

Table 1: Main values used for the simulation

	Value	Unit	Value	Unit
L_1	2.59	m	8.50	ft
L_2	3.29	m	10.79	ft
L_3	3.97	m	13.02	ft
L_4	5.45	m	17.88	ft
w	2.44	m	8.0	ft

W_t	23472	Kg	51746	lb
W_c	8444	Kg	18616	lb
μ_f	.2 to .8		.2 to .8	
μ_m	.2 to .8		.2 to .8	
μ_r	.2 to .8		.2 to .8	
I_t	181565.5	Kg m ²	133951.7	Slug ft ²

Case 1: Trailer's tires with different coefficients of friction

In rainy conditions water might accumulates on the side of the road. As a result, the coefficient of friction of the right and the left tires will be different. To simulate these conditions it is assumed, in this simulation, that the right rear trailer's tires have lower coefficient of friction than the other tires. Figure 6 illustrates the angular displacement of the trailer for three different coefficients of friction. It is clear that for a coefficient of friction 0.2 the truck becomes unstable. Also, as shown in Figure 7, the braking distance if being affected even though only one set of tires has lower coefficient of friction.

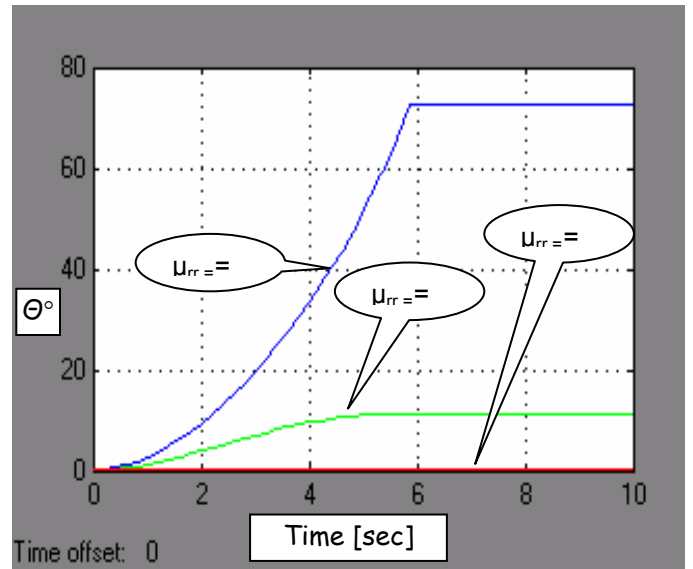
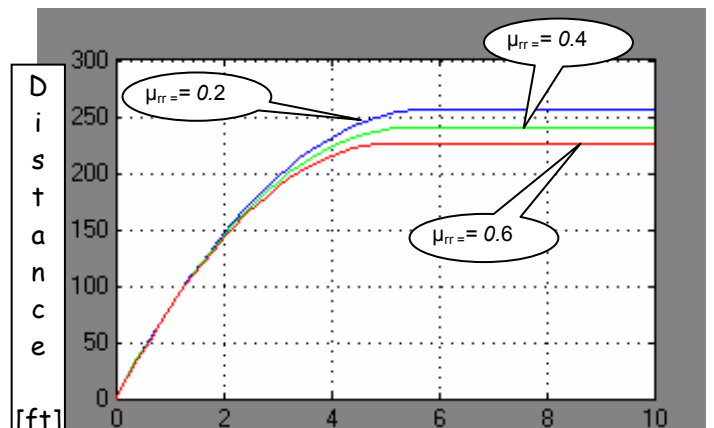

Figure 6: Trailer's angle with several coefficients



Time [sec]

Figure 7: Tractor/trailer's braking distance.

Case 2: The effect of the location of trailer's center of gravity

Although this aspect is rarely studied in the jackknife simulation and modeling, it seems natural to think that an articulated truck-trailer whose trailer is not symmetrically loaded has more chance to jackknife than another one whose trailer is perfectly loaded.

Instead of doing simulations with several values of the distances between the trailer's CG and the wheels to know their effects on the behavior, the following simulation compares four different loadings in which the center of gravity is shifted right to left and front and rear as shown below:

- C1 - $L_3 = 10,5$ ft, $L_4 = 20,5$ ft & $b = 6$ ft
- C2 - $L_3 = 10,5$ ft, $L_4 = 20,5$ ft & $b = 2$ ft
- C3 - $L_3 = 20,5$ ft, $L_4 = 10,5$ ft & $b = 6$ ft
- C4 - $L_3 = 20,5$ ft, $L_4 = 10,5$ ft & $b = 2$ ft

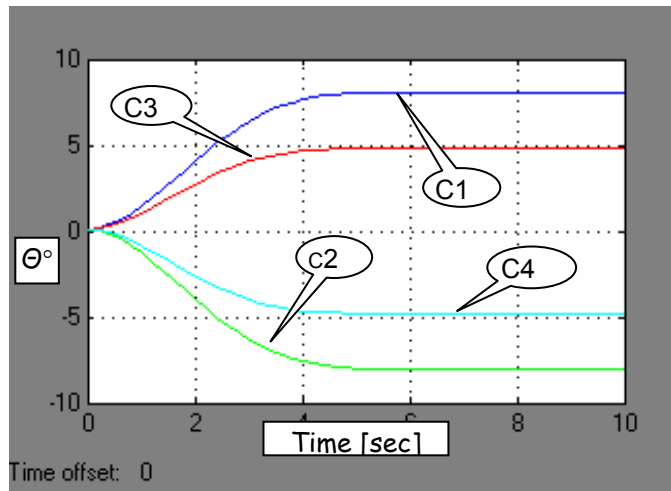

Figure 8: Trailer's angle with different loadings.

Figure 8 indicates that in this case where the coefficient of friction of all tires is the same, there is no effect of shifting the load from right to left (C1 is symmetric to C2 and C3 to C4). Obviously, shifting the center of gravity to the front of the trailer (C3 and C4) will contribute to occurrence of jackknifing due to reduction of friction forces on the trailer's tires.

Case 3: Low coefficient on the tractor's front wheels.

Some reports claim that the jackknifing might occur if the coefficient friction on the front and middle wheels is too low since the tires could not provide the friction force required to stop the trailer. To examine this claim the tractor's tires coefficient of friction was set to a low value and the simulation was performed.

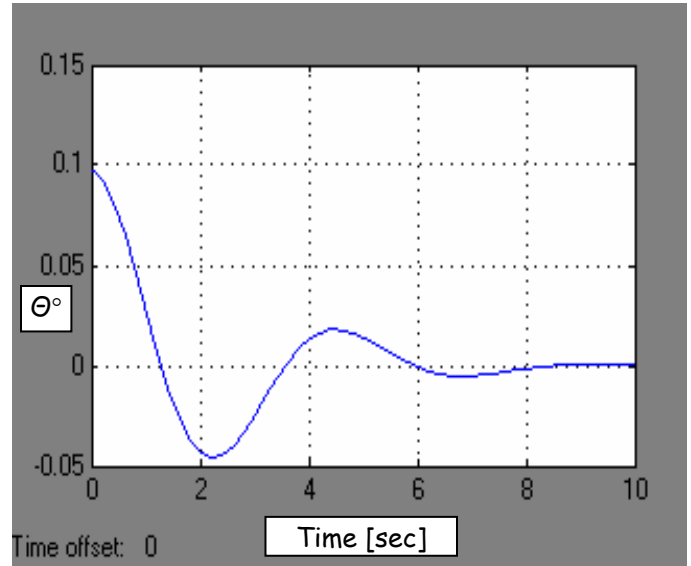

Figure 9: Trailer's angle with lower coefficients of friction on the tractor's tires.

The results shown in Figure 9 are quite surprising. Although the braking distance and the braking time have increased, the semi-trailer seems to remain stable under certain circumstances.

Conclusion

As a conclusion it is easier to come to an unstable case with the two dimensional model, indeed there are the one dimensional unstable cases and the cases where the trailer is not symmetrically loaded or the coefficient of friction on the rear wheels are not the same. The tractor/trailer may also become unstable if the gravity center is moved forward or behind and if it is not located on the trailer symmetry axis or if the coefficients of friction of the rear wheels are not the same.

Hence, according to this model a tractor semi-trailer could become unstable if it is braking in a non regular surface area that is to say water or grease under one of the rear wheels for example or even if the brakes don't work correctly on one wheel.

Changing some other parameters such as the initial conditions and particularly the initial speed of the tractor may also change the behavior of the tractor trailer combination. In fact those changes may increase the speed of the reaction and lead the trailer to the limit of stability.

Maybe, the jackknife problem is not as simple as seen before. During the braking the coefficient of friction may decrease if the wheel is locked or if it is heated. Moreover

why should the coefficient of friction be the same as the wheel is skidding forward or on any other direction.

Contact

Oren Masory can be contacted by post at Mechanical Engineering Department, Florida Atlantic University, Boca Raton, FL 33431, or via email at masoryo@fau.edu.

References

1. The American Trucking Association, <http://www.truckline.com>
2. Fossum, T. V., and Lewis, G., "A mathematical model for trailer-truck jackknifing", *SIAM Review* **23** 1981.
3. Chieh Chen and Masayoshi Tomizuka , "Modeling and Control of Articulated Vehicles", University of California, Berkeley, UCB-ITS-PRR-97-42, November 1997, ISSN 1055-1425
4. Dr Bruce P. Minaker, University of Windsor, Ontario, Canada, <http://charger.esx2f.uwindsor.ca/~minaker/index.html>
5. Meihua Tai, Jeng-Yu Wang, Pushkar Hingwe, Chieh Chen, Masayoshi Tomizuka "Lateral Control of Heavy Duty Vehicles for Automated Highway Systems", University of California, Berkeley, UCB-ITS-PRR-98-8, February 1998, ISSN 1055- 1425
6. J. Christian Gerdes, Paul Yih, Krishna Satyan, "Safety Performance and Robustness of Heavy Vehicle AVCS", Stanford University, January 2002
7. Wen-Hou Ma and Huei Peng, "Worst-Case Vehicle Evaluation Methodology—Examples on Truck Rollover/Jackknifing and Active Yaw Control Systems", *Vehicle System Dynamics*, 32 (1999), pp.389–408 0042-3114/99/3204-389
8. Richard W. Radlinski, "The anatomy of a tractor trailer jackknife", President Radlinski & Associates, Inc, <http://www.raibrakes.com>
9. K & R. Gieck, "Formulaire Technique", Gieck Verlag, Edition française 1990, ISBN 3 920 379 187
10. U.S. Department of Transportation's, "Transportation Comprehensive Truck Size and Weight Study", Volume II, Issues and Background, Publication Number: FHWA-PL-00-029 (Volume II), HPTS/August 2000.

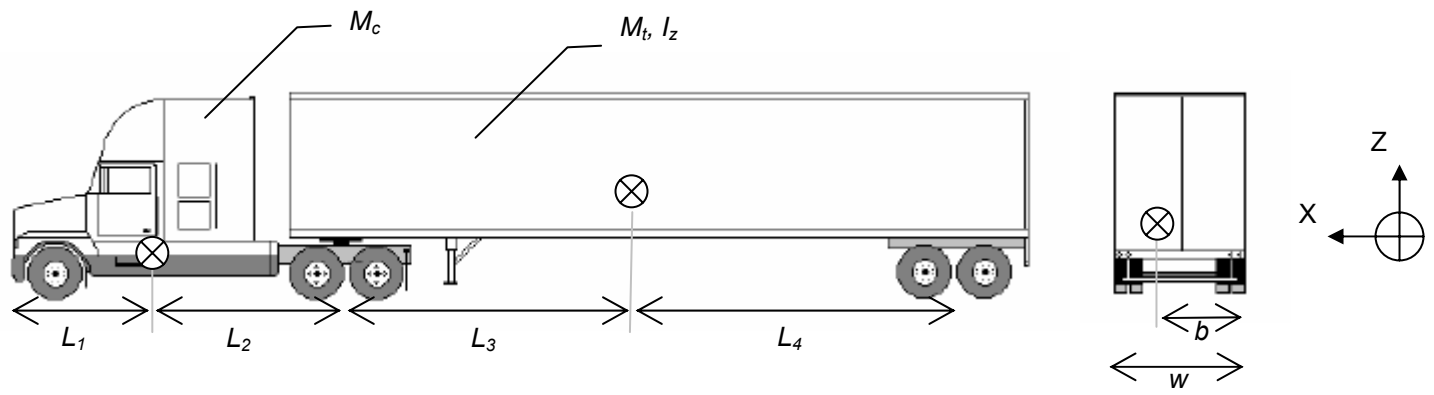

Figure 1: Tractor Semi trailer Dimensions.

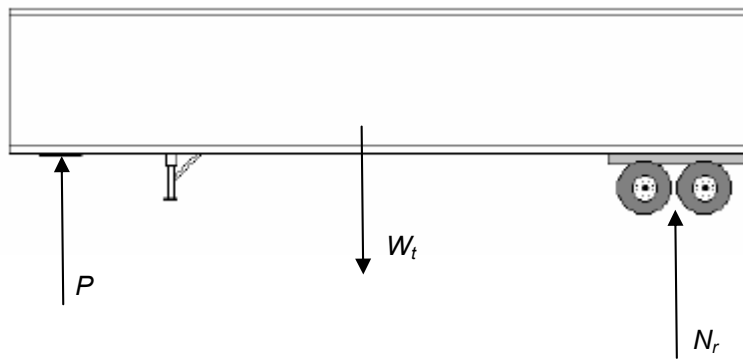

Figure 2: Vertical forces acting on the tractor.

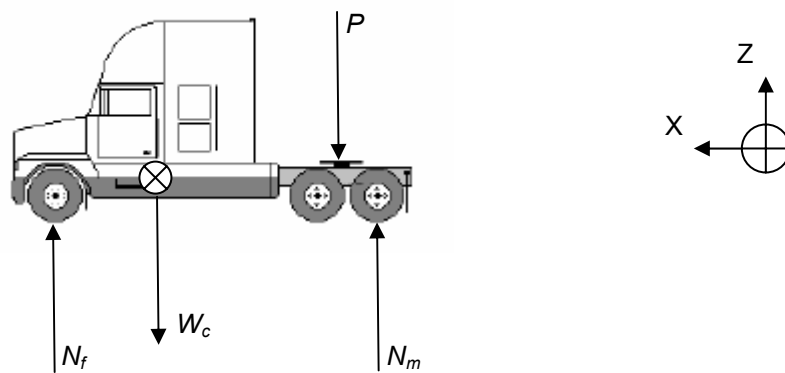

Figure 3: Vertical forces acting on the trailer

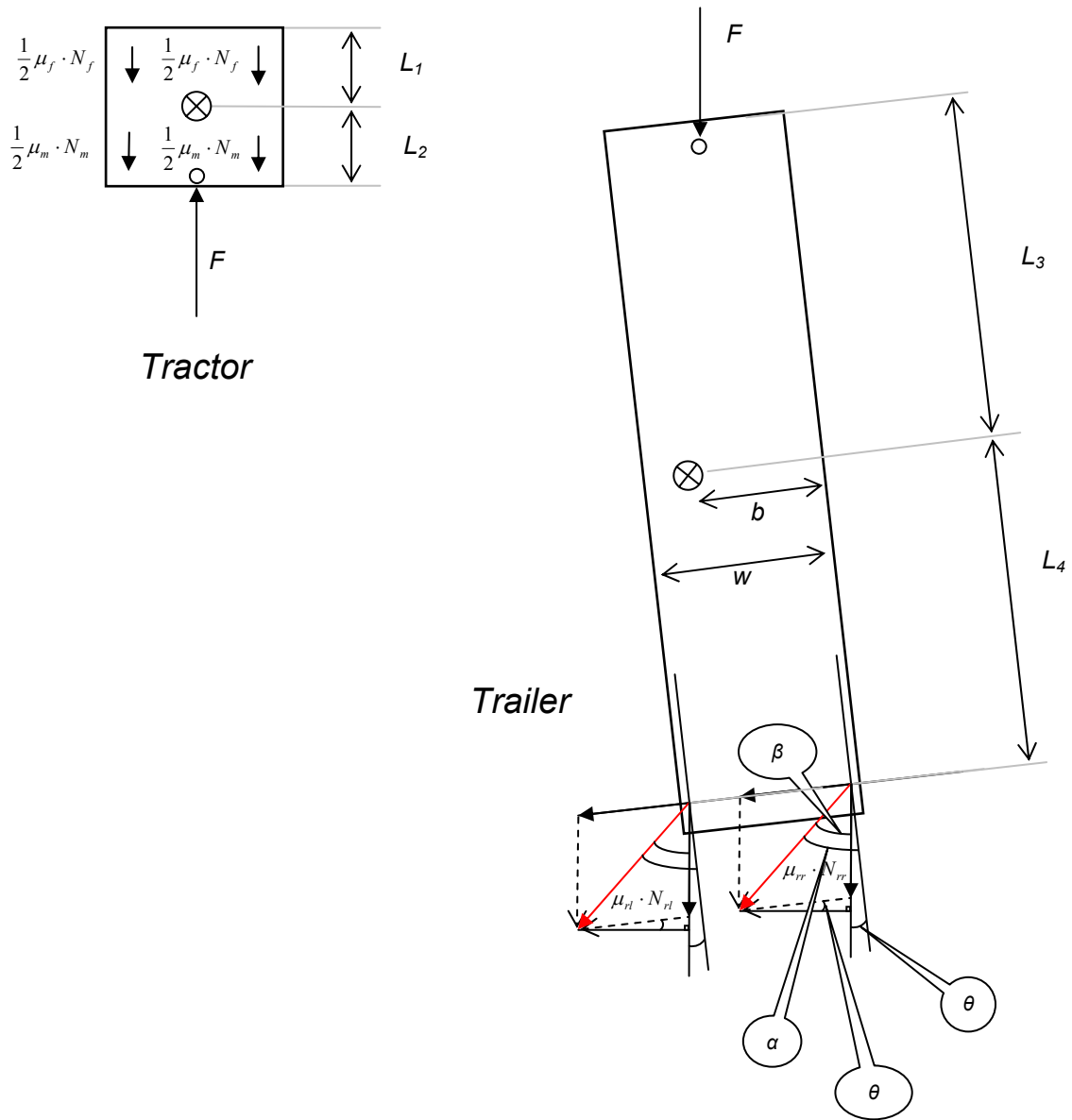

Figure 4: Horizontal forces acting on the tractor and the trailer.

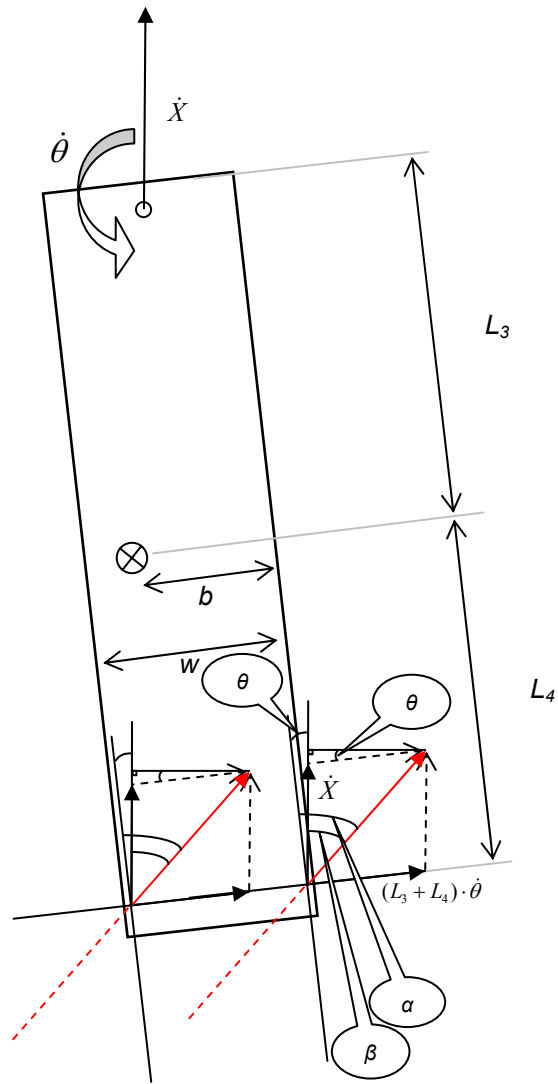

Figure 5: Velocities on the trailer.